



Nominal data

Type	3414 NHH	
Nominal voltage	VDC	24
Nominal voltage range	VDC	18 .. 26
Speed (rpm)	min ⁻¹	3250
Power consumption	W	3.1
Min. ambient temperature	°C	-20
Max. ambient temperature	°C	70
Air flow	m ³ /h	102
Sound power level	B	5.1
Sound pressure level	dB(A)	39

ml = Max. load · me = Max. efficiency · fa = Free air · cs = Customer specification · ce = Customer equipment
Subject to change

Technical description

Housing material	Glass-fiber reinforced PBT plastic
Impeller material	Glass-fiber reinforced PA plastic
Weight	0.100 kg
Dimensions	92 x 92 x 25 mm
Airflow direction	Exhaust over struts
Direction of rotation	Counterclockwise, viewed toward rotor
Storage	Ball bearing
Service life L10 at 40 °C	70000 h
Service life L10 at maximum temperature	35000 h
Cable	Leads AWG 24, TR 64, stripped and tin-plated.
Motor protection	Protection against reverse polarity and blocked rotor.
Approval	VDE, CSA, UL
Option	Alarm signal

Product drawing

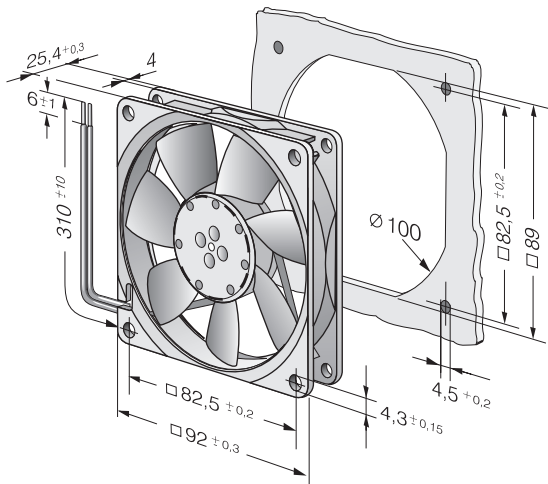

Curves: Air performance

